

MODEL PL-UV1

UV DISINFECTION SYSTEM

INSTALLATION AND OPERATION MANUAL

The installer should provide a power disconnect switch mounted to the exterior of the facility being served to de-energize power to the unit during maintenance. Electrical work must be performed in accordance with the latest edition of the National Electrical Code, as well as all applicable local codes. The Polylok UV disinfection system conforms to the applicable provisions of the Code of Federal Regulations (CFR) requirements including Title 21, Chapter 1, Subchapter J, Radiological Health. **CAUTION: DO NOT LOOK DIRECTLY AT THE UV LAMP OR EXPOSE SKIN DURING OPERATION. PERMANENT EYE DAMAGE AND SKIN BURNS WILL OCCUR FROM UV RADIATION EXPOSURE. UV BLOCKING SAFETY GLASSES MUST BE WORN DURING INSTALLATION, SERVICE OR ANY TIME THE LAMP MAY BE ILLUMINATED. UV BLOCKING SAFETY GLASSES ARE AVAILABLE FROM NORWECO.**

COMPONENTS

The Model PL-UV1 disinfection system consists of the following components:

- | | |
|---------------------------------------|--|
| 1) Control enclosure | 7) Power cable with female twist lock connector |
| 2) 4" ABS riser pipe | 8) UV subassembly with quartz sleeve and Teflon sheath |
| 3) 4" ABS inlet coupling | 9) Subassembly handle |
| 4) 4" ABS outlet coupling | 10) Turbulence inducer |
| 5) Disinfection chamber | |
| 6) UV lamp (bulb) with male connector | |

These components should be supplied by the installer:

- | | |
|------------------------|-------------------------------|
| 1) Disconnect switch | 6) Isopropyl alcohol |
| 2) Solvent cement | 7) #14/2 AWG cable |
| 3) Hacksaw | 8) Conduit and fittings |
| 4) Glycerin (optional) | 9) Flat head screwdriver |
| 5) Clean, soft cloth | 10) Phillips head screwdriver |

INSTALLATION INSTRUCTIONS

1. The excavation for the upstream wastewater treatment system should include an additional 3 feet of length to allow for installation of the Model PL-UV1.
2. Carefully unpack the Model PL-UV1 system. Remove and properly discard all packaging materials from the system components. The UV lamp should remain in the protective shipping sleeve until it is installed.
3. Insert the turbulence inducer into the 4" inlet coupling. Solvent weld the inlet coupling to the disinfection chamber with the turbulence inducer towards the chamber. Solvent weld the 4" outlet coupling to the disinfection chamber.

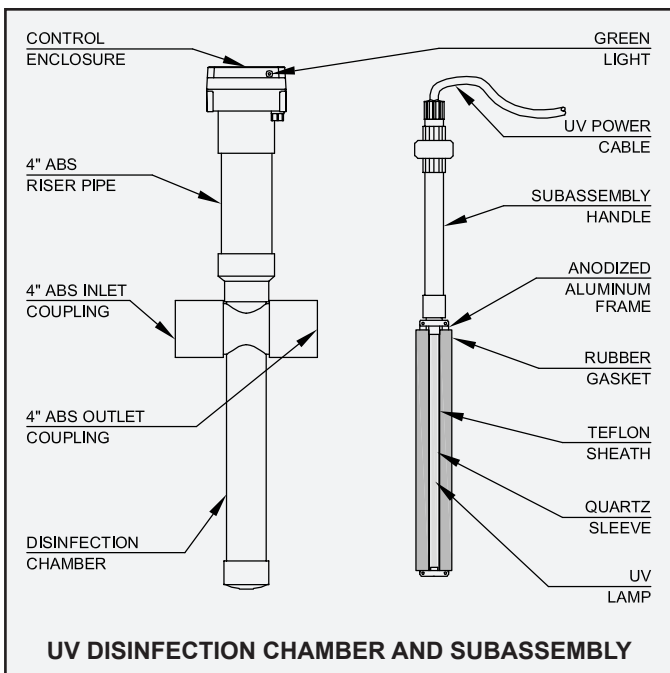
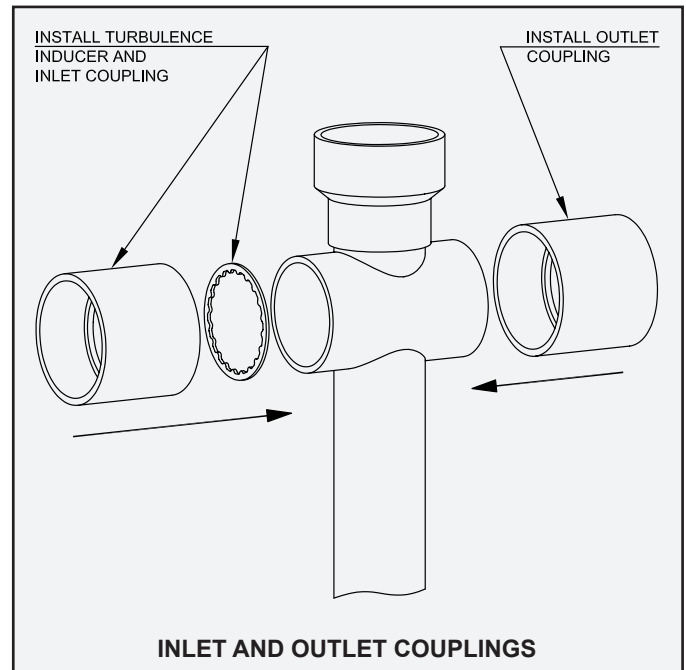

4. Solvent weld the effluent line of the upstream treatment system to the 4" inlet coupling of the Model PL-UV1. Next, solvent weld the 4" outlet coupling to the final effluent line. Cover the open top of the disinfection chamber and backfill up to the bottom of the plumbing.

UV DISINFECTION INSTALLATION AND OPERATION (Cont.)

5. The control enclosure should be completely above grade in the finished installation. The riser pipe and subassembly handle are purposely manufactured longer than necessary and must be trimmed. Fit the riser pipe into the top of the disinfection chamber and mark a trim line on the bottom. Mark the subassembly handle on the bottom to trim the same amount.

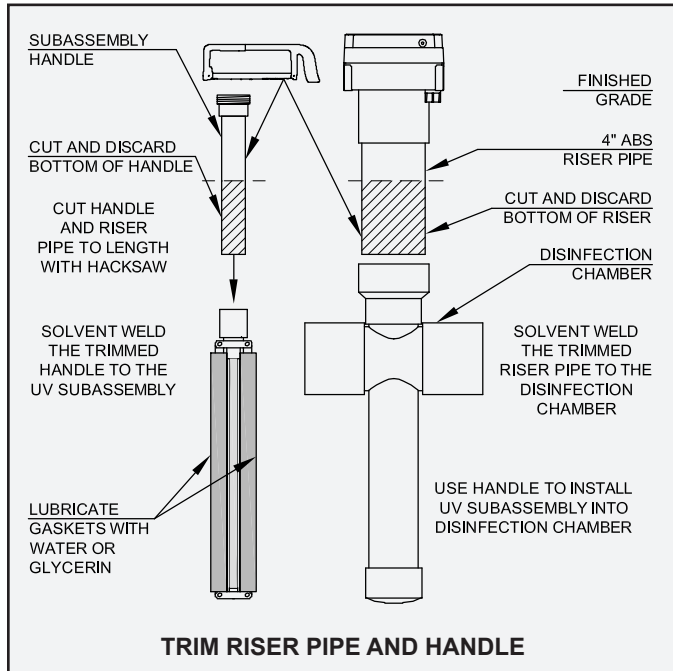

6. Disassemble the union on subassembly handle and set aside the top portion with UV power cable.
 7. Use a hacksaw to cut along the trim line on both the riser pipe and handle to make them the proper length.
 8. Solvent weld the riser pipe to the disinfection chamber and solvent weld the handle to the UV subassembly.
 9. The Model PL-UV1 is shipped with the UV power cable connected to the control enclosure. If this power cable

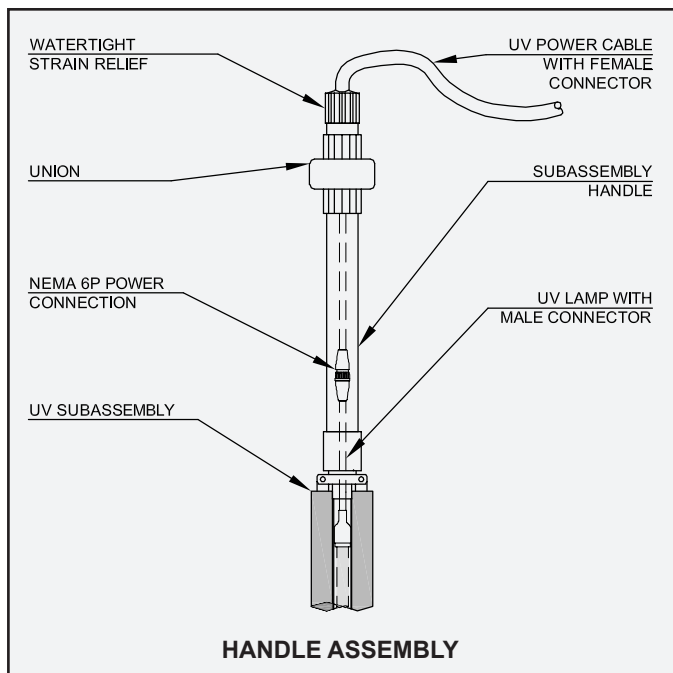

has become disconnected, it must be reconnected at this time. To do so, remove the gasketed cover from the control enclosure. Connect the lead labeled "ONE" on the UV power cable to the terminal block marked "1". Connect the lead labeled "TWO" to the terminal block marked "2". Connect the lead labeled "THREE" to the terminal block marked "3". Connect the yellow/green lead to the terminal marked "Y/G".

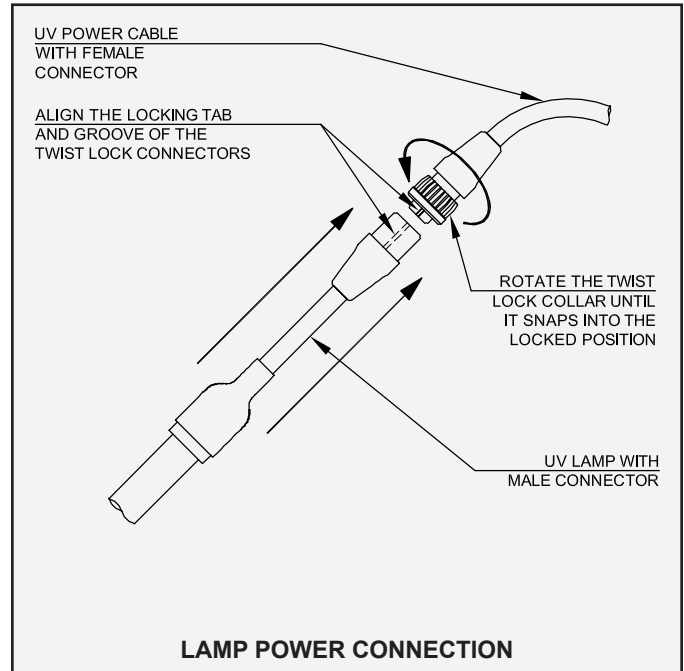

10. Remove the threaded access plug from the riser pipe.
 11. Match the alignment tab on the male connector from the UV lamp to the alignment groove in the female twist lock connector on the 6 ft. UV power cable. Push the two connectors together until the male connector is fully seated in the female connector. Rotate the twist lock collar until it snaps into the locked position.
 12. Insert the UV lamp and power cable into the handle assembly until the base of the lamp is seated in the bottom of the quartz sleeve. Rotate the power cable if the lamp becomes misaligned.
 13. Lower the union onto the handle assembly, making sure to pull any slack cable through the strain relief connector. Assemble and tighten the union and strain relief to insure a watertight seal.
 14. Use water or glycerin to lubricate the rubber gaskets located on both sides of the UV subassembly.
 15. Do not touch the Teflon sheath or allow excess glycerin to contact it. Use a clean, soft cloth and isopropyl alcohol to thoroughly clean the sheath.
 16. Fill the disinfection chamber with clean water.

MANUFACTURED BY



POLYLOK, INC.
 3 FAIRFIELD BLVD
 WALLINGFORD, CT
 U.S.A. 06492
 www.polylok.com

UV DISINFECTION INSTALLATION AND OPERATION (Cont.)

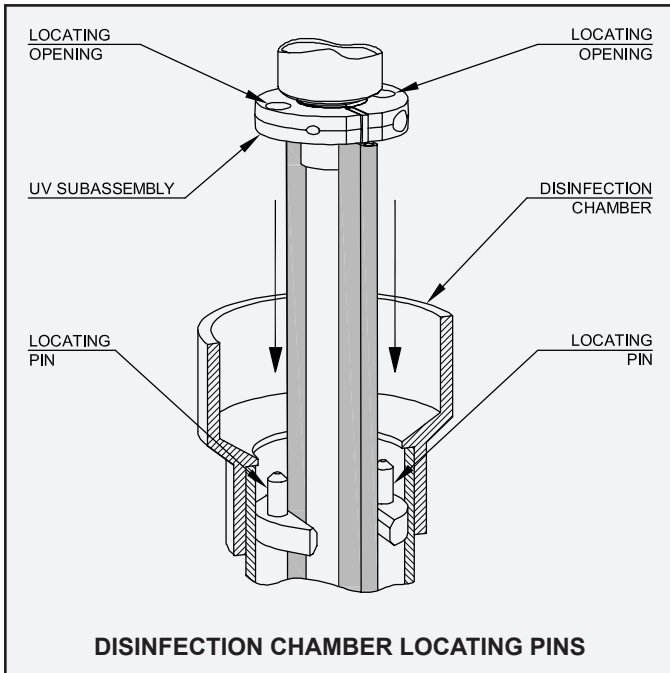

17. Insert UV subassembly into the disinfection chamber. Insure locating pins fully engage locating openings.
18. Tuck the excess power cable into the riser pipe.
19. Use a dedicated 115 volt AC single phase 15 amp circuit in the main electrical panel for the Model PL-UV1. **NOTE:** Make sure the breaker is off before proceeding.
20. Use a disconnect switch to de-energize power during service. Mount directly to the facility being served.
21. Install a #14/2 AWG cable from the dedicated breaker in the main electrical panel to the disconnect switch.
22. In the disconnect switch enclosure, connect the hot (black) lead from the main electrical panel to the "LINE" terminal. Connect the black lead from the UV system to the "LOAD" terminal. Wire nut both white leads together. Connect ground leads to the ground lug.

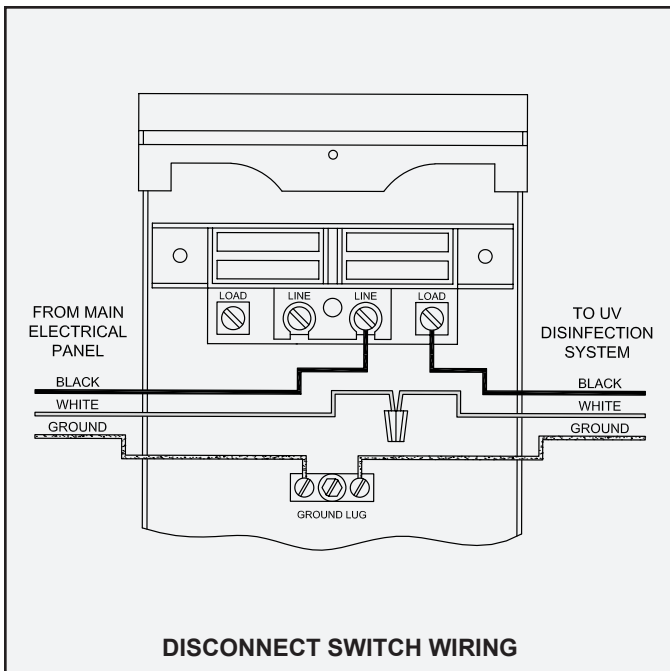

23. Remove the control enclosure cover and black electrical insulator. Install a #14/2 AWG cable from the disconnect switch to the control enclosure. Insure the connection to the UV system is made in conduit, solvent welded to the conduit fitting provided. A watertight connection is critical for proper operation and safety.
24. Attach the incoming hot (black) lead to the terminal block marked "LINE". Attach the common (white) lead to the terminal block marked "NEUT". Attach the incoming ground lead to the terminal block marked "GROUND".
25. If a remote alarm panel is required, the alarm leads should be installed in a separate conduit, solvent welded to the second conduit fitting provided. Connect one alarm lead to either the normally open (NO) terminal or the normally closed (NC) terminal. Choose the correct terminal for the type of signal required by the remote alarm panel. Connect the other lead to the common (COM) terminal.
26. Solvent weld a conduit plug into any unused fittings.
27. Apply thread sealant to the access plug and install plug in the riser opening. Tighten to insure a watertight seal.

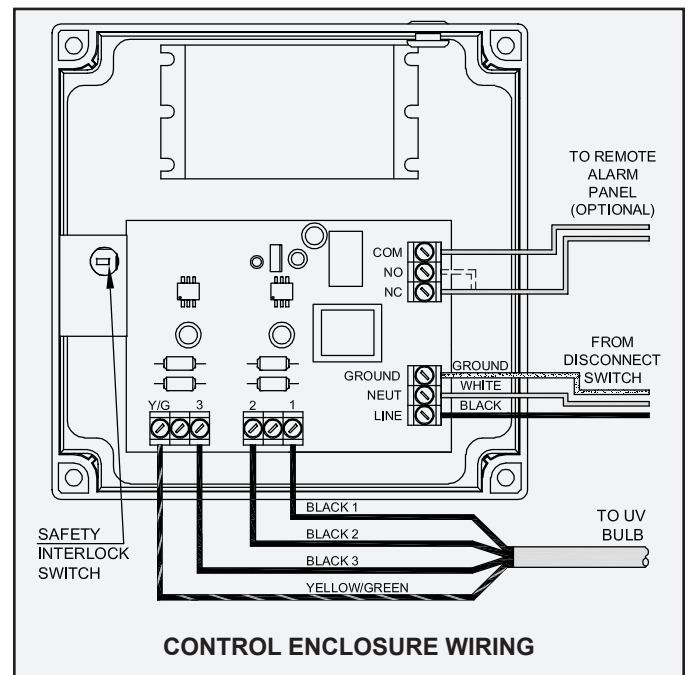

28. Reinstall the electrical insulator and four thumb screws. Make sure that the cutout for the safety interlock switch is positioned correctly over the switch.
29. Reinstall the control enclosure cover, insuring that the safety interlock post is aligned with the safety interlock switch. Tighten the four screws on the cover to insure a watertight seal. **NOTE:** If the switch is not aligned with the post, the UV lamp will not operate and the green light on the side of the enclosure will not illuminate.
30. Backfill around the disinfection chamber and riser pipe. Finished grade should be below the control enclosure to prevent the entry of surface water.
31. Turn on power at the disconnect switch and main service panel. Confirm the green light on the enclosure is illuminated indicating proper operation.

UV DISINFECTION INSTALLATION AND OPERATION (Cont.)

MAINTENANCE AND SERVICE

UV blocking protective eyewear must be worn during service or any time the lamp may be illuminated. It is recommended that the subassembly be removed and serviced every six months to insure proper disinfection. Inspect the Teflon sheath for damage or biological film. If the sheath is damaged or biological film is present between the sheath and the quartz sleeve, the subassembly must be replaced. Contact Polylok for replacement parts. If biological film is present on the surface of the Teflon sheath, the sheath must be cleaned to insure proper disinfection. To clean the Teflon sheath:

1. Turn off power to the UV system at the disconnect switch and/or main service panel. Confirm that the green light on the side of the enclosure is off.
2. Remove the control enclosure cover and access plug.
3. Use a soft damp cloth to carefully and thoroughly clean the Teflon sheath.
4. Use isopropyl alcohol on a soft cloth to carefully remove difficult stains like fingerprints or biological film.

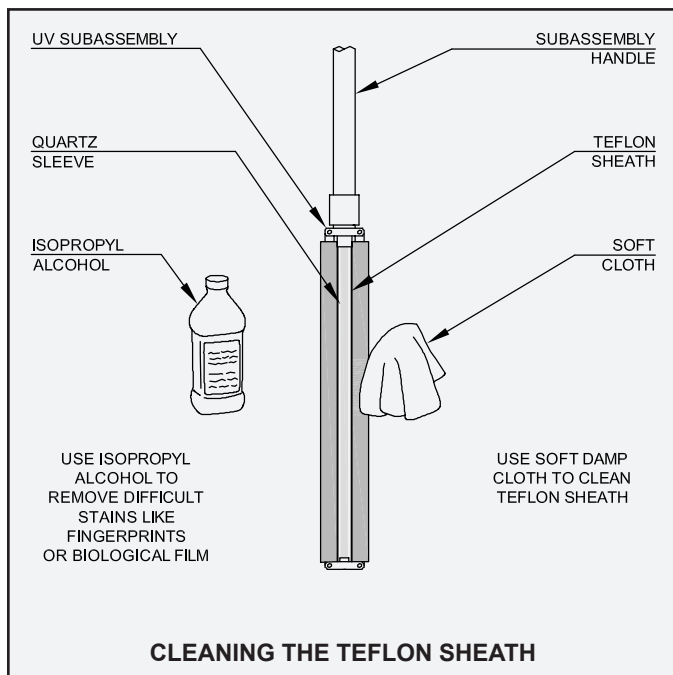

The system is designed to provide long service life. It is recommended that the UV lamp be replaced every two years to insure proper disinfection of the treatment system effluent. The green light on the side of the control enclosure will no longer illuminate when the lamp needs replaced. UV blocking protective eyewear must be worn during service or any time the lamp may be illuminated. To replace the lamp:

1. Repeat steps 1 and 2 above.
2. Remove the subassembly from the disinfection chamber and disassemble the union in the handle. Use the power cable to remove the UV lamp.
3. Disconnect the UV lamp from the UV power cord by rotating the twist lock collar $\frac{1}{4}$ turn.

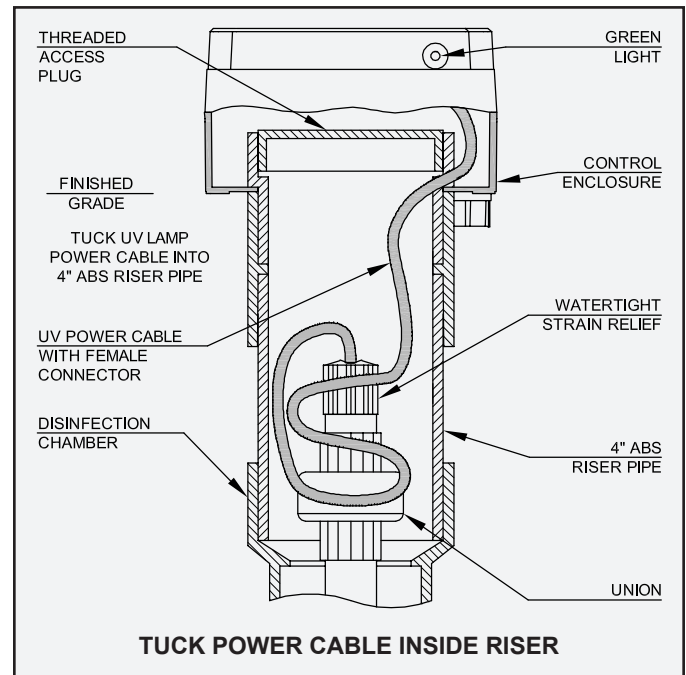

4. Connect new lamp and carefully lower into the UV subassembly. Make sure the lamp is fully seated in the quartz sleeve.
5. Reassemble union and tighten strain relief.
6. Lower the subassembly into the disinfection chamber.
7. Reinstall the threaded access plug into the riser.
8. Reinstall the enclosure cover, insuring that the safety interlock post is aligned with the safety interlock switch. Tighten the four screws to insure a watertight seal.
9. Turn on power at the disconnect switch or main service panel. Verify that the green light on the side of the control enclosure is illuminated.

NOTE: UV lamps contain mercury which is harmful to the environment. Recycle old UV lamps at an authorized center.

ALARM CIRCUIT

The Model PL-UV1 system is equipped with a current sensing circuit to monitor the UV lamp performance. If the UV lamp output drops below an acceptable level for proper disinfection, the alarm circuit will turn off the green light on the enclosure. When connected to a telemetry system, the service provider can be immediately notified that maintenance to the UV system is required. For more information regarding connection of the Model PL-UV1 UV disinfection system to an alarm control center, please refer to the Installation and Operation Instructions.

MANUFACTURED BY

POLYLOK Inc.
www.polylok.com 1.888.765.9565

POLYLOK, INC.
3 FAIRFIELD BLVD
WALLINGFORD, CT
U.S.A. 06492
www.polylok.com