

Control Switch Installation Instructions

SJE-Rhombus® narrow angle control switches accurately monitor liquid levels in sewage, and non-potable water applications. These switches are designed to activate pump control panels and alarms.

The SJE SignalMaster® and SJE SignalMaster® SPDT control switches passed NSF Standard 61 protocol by an approved Water Quality Association laboratory for use in potable water applications.

SJE SIGNALMASTER®



- Mechanically activated.
- Control differential of 1.5 inches above or below horizontal.
- Not sensitive to rotation.
- Mounting options: mounting clamp or cable weight.

SJE SIGNALMASTER® SPDT



- Mechanically activated.
- Control differential of 1.5 inches above or below horizontal.
- Not sensitive to rotation.
- Mounting options: mounting clamp or cable weight.

SENSOR FLOAT®



- Mercury activated.
- Suitable for use with an intrinsically safe circuit.**
- Not sensitive to rotation.
- Mounting options: mounting clamp, internal or cable weight.

**Contact SJE-Rhombus for specific intrinsically safe applications.

SENSOR FLOAT® MINI



- Mercury activated.
- Narrow angle float switch in a small float housing.
- Suitable for use with an intrinsically safe circuit.**
- Not sensitive to rotation.
- Mounting options: mounting clamp or cable weight.

**Contact SJE-Rhombus for specific intrinsically safe applications.

PREVENTATIVE MAINTENANCE

- Periodically inspect the product. Check that the cable has not become worn or that the housing has not been damaged so as to impair the protection of the product. Replace the product immediately if any damage is found or suspected.
- Periodically check to see that the float is free to move and operate the switch.
- Use only SJE-Rhombus® replacement parts.
- The Sensor Float® and Sensor Float® Mini control switches contain mercury and MUST be recycled or disposed of according to local, state, and federal codes.

SJE-RHOMBUS® THREE-YEAR LIMITED WARRANTY

SJE-RHOMBUS® warrants to the original consumer that this product shall be free of manufacturing defects for three years after the date of consumer purchase. During that time period and subject to the conditions set forth below, SJE-RHOMBUS® will repair or replace, for the original consumer, any component which proves to be defective due to defective materials or workmanship of SJE-RHOMBUS®.

THIS EXPRESS WARRANTY DOES NOT APPLY TO THE MOTOR START KIT COMPONENT. SJE-RHOMBUS® MAKES NO WARRANTIES OF ANY TYPE WITH RESPECT TO THE MOTOR START KIT.

ELECTRICAL WIRING AND SERVICING OF THIS PRODUCT MUST BE PERFORMED BY A LICENSED ELECTRICIAN.

THIS WARRANTY DOES NOT APPLY: (A) to damage due to lightning or conditions beyond the control of SJE-RHOMBUS®; (B) to defects or malfunctions resulting from failure to properly install, operate or maintain the unit in accordance with printed instructions provided; (C) to failures resulting from abuse, misuse, accident, or negligence; (D) to units which are not installed in accordance with applicable local codes, ordinances, or accepted trade practices, and (E) to units repaired and/or modified without prior authorization from SJE-RHOMBUS®.

Some states do not allow limitations on how long an implied warranty lasts, so the above limitation may not apply to you. Some states do not allow the exclusion or limitation of incidental or consequential damages, so the above limitation or exclusion may not apply to you. This warranty gives you specific legal rights, and you may also have other rights which vary from state to state.

TO OBTAIN WARRANTY SERVICE: The consumer shall assume all responsibility and expense for removal, reinstallation, and freight. Any item to be repaired or replaced under this warranty must be returned to SJE-RHOMBUS®, or such place as designated by SJE-RHOMBUS®.

ANY IMPLIED WARRANTIES OF MERCHANTABILITY OR FITNESS ARE LIMITED TO THE DURATION OF THIS WRITTEN WARRANTY. SJE-RHOMBUS® SHALL NOT, IN ANY MANNER, BE LIABLE FOR ANY INCIDENTAL OR CONSEQUENTIAL DAMAGES AS A RESULT OF A BREACH OF THIS WRITTEN WARRANTY OR ANY IMPLIED WARRANTY.

WARNING**ELECTRICAL SHOCK HAZARD**

Disconnect power before installing or servicing this product. A qualified service person must install and service this product according to applicable electrical and plumbing codes.

WARNING**EXPLOSION OR FIRE HAZARD**

Do not use this product with flammable liquids. Do not install in hazardous locations as defined by National Electrical Code, ANSI/NFPA 70.

Failure to follow these precautions could result in serious injury or death. Replace product immediately if switch cable becomes damaged or severed. Keep these instructions with warranty after installation. This product must be installed in accordance with National Electric Code, ANSI/NFPA 70 so as to prevent moisture from entering or accumulating within boxes, conduit bodies, fittings, float housing, or cable.

For detailed specifications on this product, or for the complete line of SJE-Rhombus® panel, alarm, and switch products, visit our web-site at www.sjrhombus.com.

MOUNTING THE SWITCH

WARNING: Do not install switch in direct line of incoming liquid.

1. Place the cord into the clamp as shown in Figure C.
2. Locate clamp at desired activation level and secure the clamp to the discharge pipe as shown in Figures A and B.
Note: Do not install cord under hose clamp.
3. Tighten the hose clamp using screwdriver. Over tightening may result in damage to the plastic clamp. Make sure the float cable is not allowed to touch the excess hose clamp band during operation.
4. Wire switch as shown in Figure D.
5. Check installation. Allow system to cycle to insure proper operation.

Note: All hose clamp components are made of 18-8 stainless steel material. See your SJE-Rhombus® supplier for replacements.

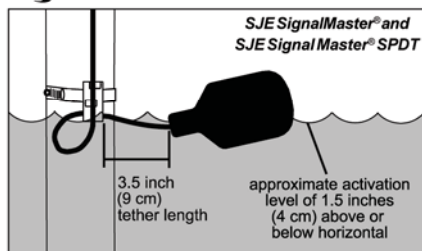
Figure A**CABLE WEIGHT**

1. Determine desired activation level.
2. Suspend switch and cable weight at desired activation level as shown in Figure E.
3. Wire switch as shown in Figure D.
4. Check installation. Allow system to cycle to insure proper operation.

To adjust cable weight tether length:

1. Release clip.
2. Adjust cable weight to desired position.
3. Lay switch cable in weight channel.
4. Align clip with weight channel and slide towards switch cable as shown in Figure E.
5. Snap clip snugly up to cable, moving clip to tightest possible position.

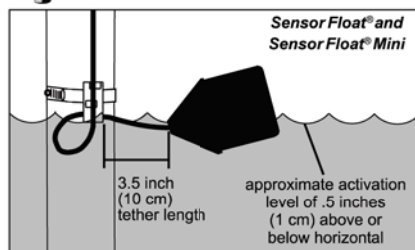
Figure B**INTERNAL WEIGHT****SENSOR FLOAT® CONTROL SWITCH ONLY**

1. Determine desired activation level as shown in Figures A & B.
2. Suspend switch 7 inches below desired activation level as shown in Figure F. Switch remains partially submerged during the "on" tipping action. Switch can be totally submerged and still continue to operate properly.
3. Wire switch as shown in Figure D.
4. Check installation. Allow system to cycle to insure proper operation.

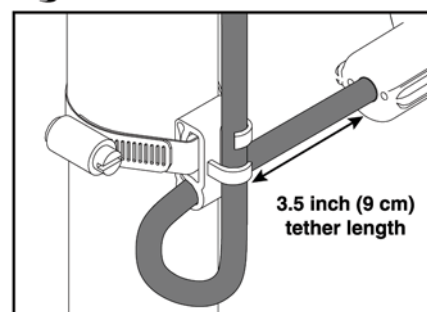
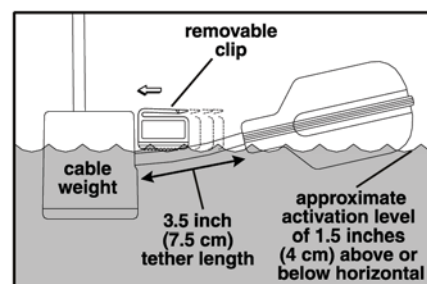
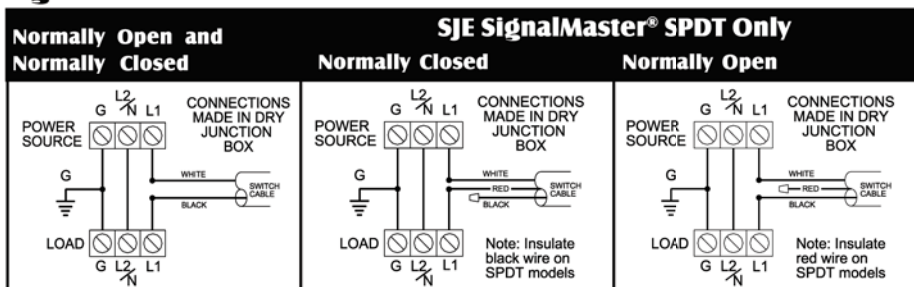
Figure C**Figure E****Figure D****WARNING**

In 230 VAC installations, one side of the line going to the load is always **HOT**. This condition exists if the switch is on or off. Install double pole disconnect on all 230 VAC circuits.

On SPDT Models, insulate unused red or black wires with wire nut. Wire can become electrically hot.

Ensure cable connections are performed in a **dry** junction box or other watertight seal that seals both conductors and cable jacket. Failure to do so could result in electrical shock hazard and/or water traveling down cable and entering the switch. Failure to guard against this may affect switch performance.

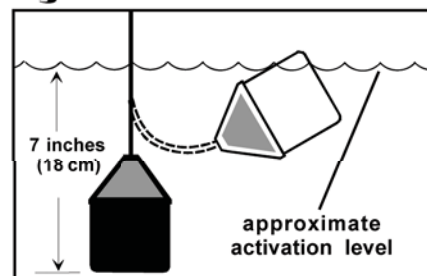
Figure F

3 Fairfield Boulevard, Wallingford, Connecticut 06492
Office: 1-877-765-9565 Fax: 203-284-8514
email: sales@polylok.com
Web site: www.polylok.com