



Universal Kid Catcher (Safety Screen)

Polylok’s safety screen protection can now be utilized on PVC Ribbed Pipe, HDPE Corrugated, and Concrete Risers with Polylok’s new Universal Kid Catcher. Everything you need is included from self tapping screws to concrete anchors and a carbide bit with it. Help save a child or pets life with this secondary form of protection.

Features:

- Concrete Risers
- Tested at 250 lbs per sq. ft
- Fits PVC Ribbed Pipe, HDPE Corrugated, and Concrete Risers
- Comes in bright orange for safety

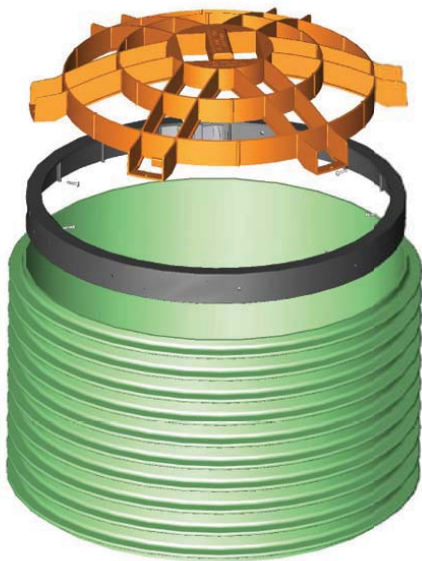

PVC Ribbed Pipe

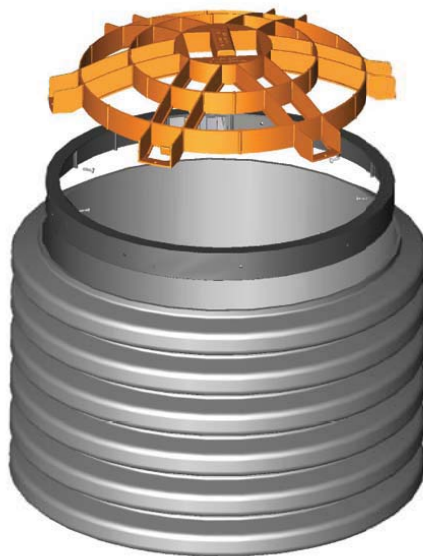

HDPE Corrugated



Concrete Risers

Riser Safety Screens

Polylok, Inc. is proud to offer our 12", 20" & 24" Safety Screens. These bright yellow, heavy-duty ABS screens act as a secondary layer of protection if the riser cover is unknowingly damaged or removed. The Riser Safety Screen fits in the upper most riser stack of our Polylok 12"x6", 20"x6", 24"x6", 20"x12" and 24"x12" risers and prevents entry into the tank. The Riser Safety Screen has been tested to 250 lbs. per sq. ft. and comes with a built in handle. For a better nights sleep, make this a part of your riser installation each and every time!

Features:

- Built in Handle
- Tested at 250 lbs per sq. ft
- Sits inside the top Riser of the Riser stack
- Comes in bright yellow for safety
- Available for 12", 20" & 24" Polylok Risers

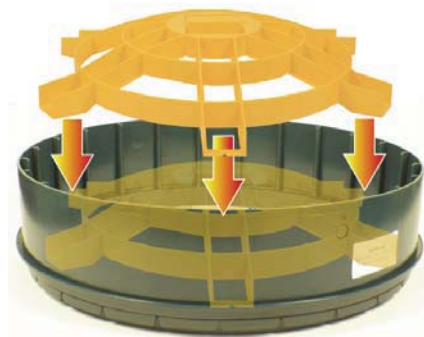

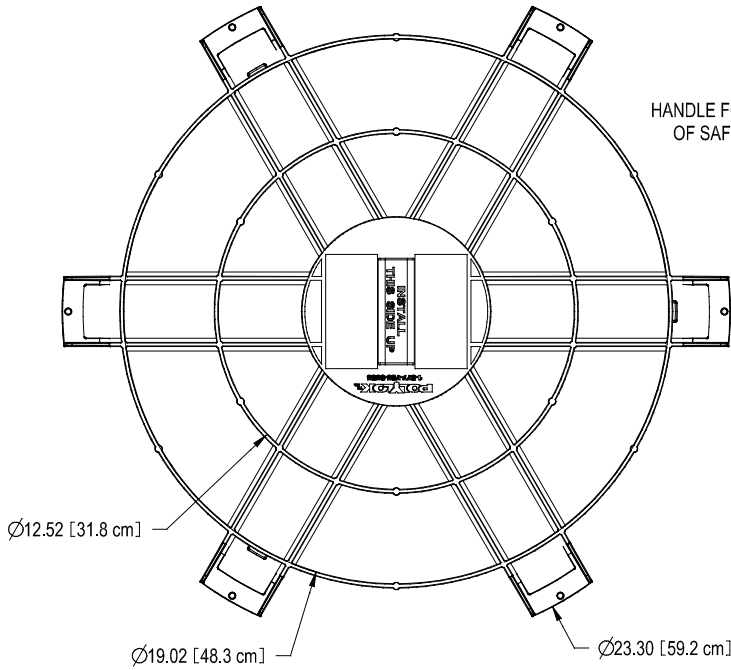

HANDLE FOR EASY REMOVAL OF SAFETY SCREEN

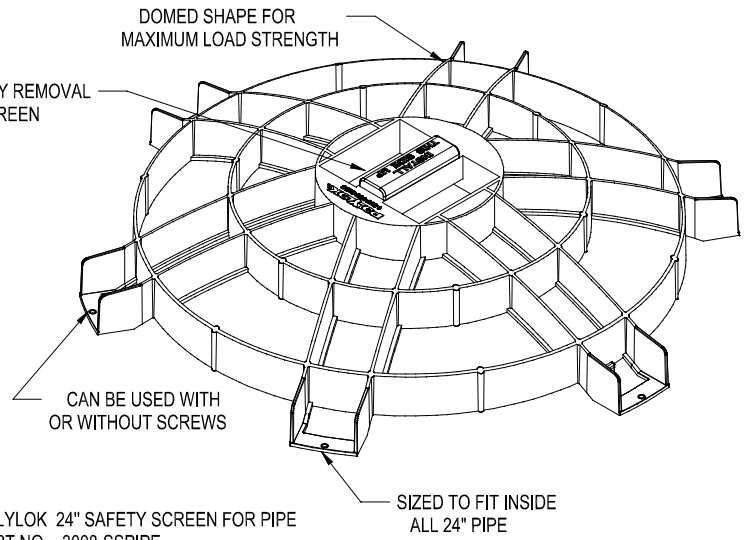

POLYLOK 24" SAFETY SCREEN FOR PIPE
 PART NO. - 3008-SSPIPE
 MATERIAL - ABS
 COLOR - ORANGE

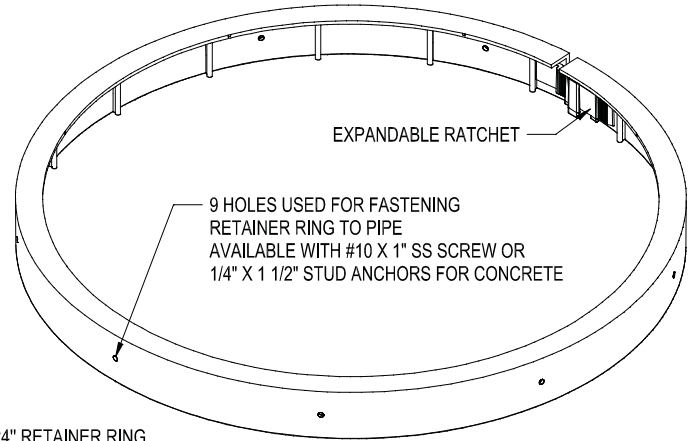
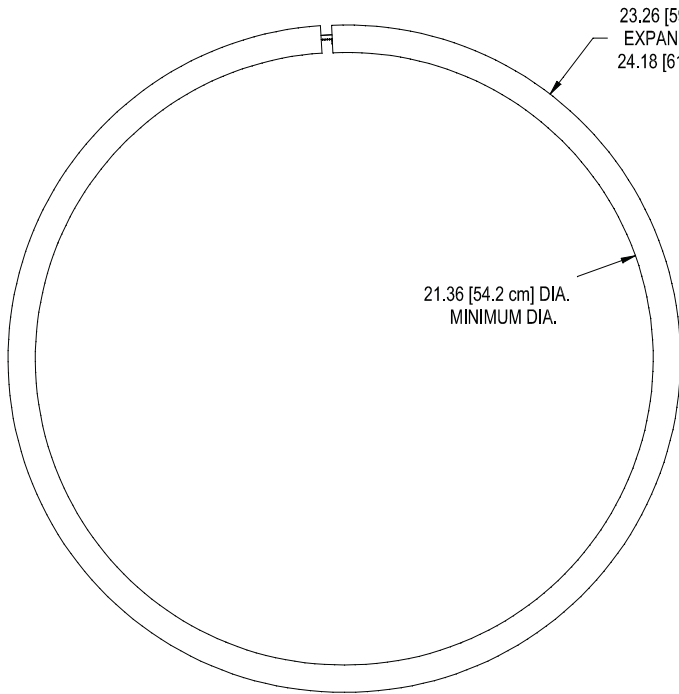
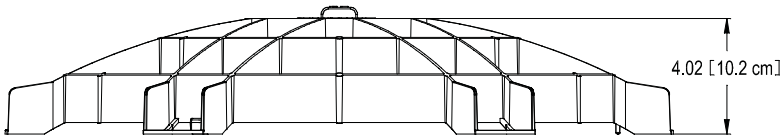

POLYLOK 24" RETAINER RING
 PART NO. - 3008-SSRPIPE
 MATERIAL - ABS
 COLOR - BLACK

